

Li-Polymer Battery

Your One-Stop Custom Battery Solution Partner

Drawing:

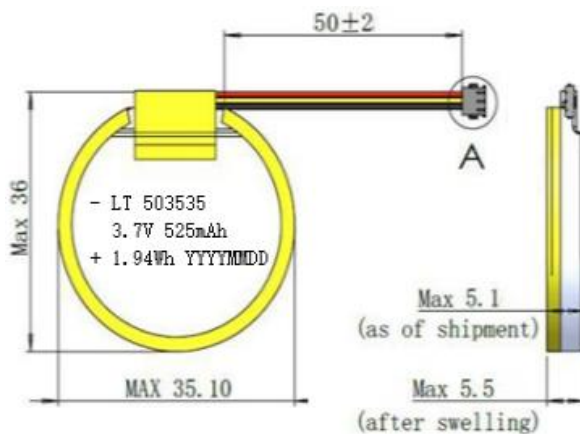

Item 项目		Rating 参数	Note 标注
1.1 Capacity 容量	Typical 标称容量	525 mAh	Temperature/温度: 25±5°C Charge/充电: 0.2C Discharge/放电: 0.2C
	Minimum 最小容量	515 mAh	
1.2 Nominal Voltage 标称电压		Average 3.7V	
1.3 AC Impedance Resistance 内阻		≤85mΩ	Cell
		≤200mΩ	Battery Pack
1.4 Discharge Cut-off Voltage 放电截止电压		3.0V	
1.5 Charge voltage 充电限制电压		4.2V	Cut-off current ≤ 10.5mA
1.6 Max Charge Continuous 最大充电电流		525mA	
1.7 Max Discharge Continuous 最大连续放电		525mA	
1.8 Weight / 重量		Approx 9g	
1.9 Cycle Life 循环寿命		500 cycles	Capacity ≥80%
1.10 Shipping Voltage / 出厂电压		3.8-4.0V	
1.11 Operating Temperature 工作温度	Charge 充电	0~+45°C	Max Charge:525mA
	Discharge 放电	-20~+60°C	Max Discharge:525mA

Model Name: LT 503535

Battery size (T*W*H): Max. 5.1*35.1*36mm Wire (L): 50±2mm (UL3302 30#) Connector: Molex78172-0300

Overcharge detection voltage 过充电检测电压: 4.255--4.305V

Overdischarge detection voltage 过放电检测电压: 2.950--3.050V

Overcurrent protection current 过电流保护电流: 1.2~3.0A

NTC: 10K B=3435K±5%

MOS: PT8205

IC: DM5268-G3J